

SyncLink GT2/GT4 Serial Adapter

Hardware User's Manual



MicroGate Systems, Ltd
13279 Pond Springs Rd #6
Austin, TX 78729
<http://www.microgate.com>

MicroGate® and SyncLink® are registered trademarks of MicroGate Systems, Ltd.
Copyright © 2008-2009 MicroGate Systems, Ltd. All Rights Reserved

Contents

Overview	3
Features	3
Specifications	3
Y-Cables.....	4
Signal Specifications.....	5
Single Ended Signals (RS-232/V.28)	5
Differential Signals (RS-422/RS-485/V.11).....	5
Clock Polarity	5
Serial Interface Selection	7
Differential Input Termination.....	8
Differential Fail-Safe Biasing	9
Serial Connector Pin Assignments	10
RS-232	11
V.35	12
RS-422/RS-449/RS-485/RS-530.....	13
X.21	15
General Purpose I/O Signals	16
DC GPIO Specifications.....	16

Overview

The SynLink GT2 and GT4 Serial Adapters are add-in cards for use in systems with a PCI expansion slot. The cards provide two (GT2) or four (GT4) serial ports for use by the system. A variety of serial protocols and interface standards are supported. Refer to the software documentation included with the card for details on using the card for a specific application.

Features

- Maximum Speeds
 - 10Mbps synchronous
 - 1.8432Mbps asynchronous with standard oscillator (14.7456MHz)
 - 4Mbps asynchronous with custom oscillator (32MHz)
- SDLC, HDLC, BISYNC, MONOSYNC, ASYNC, raw bit-synchronous protocols
- Selectable hardware CRC: CRC-16, CRC-32, None
- DPLL Clock Recovery (x8 and x16 sampling)
- Clock Generation
- Configurable transmit preamble and idle patterns
- Encoding: NRZ,NRZB,NRZ-L,NRZI,NRZ-M,NRZ-S,FM0,FM1,Manchester,differential biphas level
- Selectable interface for RS-232, V.35, RS-422/485, RS-530, RS-449, X.21
- Optional termination for differential inputs
- Optional fail safe biasing for differential inputs
- Full set of control and status signals (DTR,DSR,RTS,CTS,DCD,RI,LL,RL)

Specifications

- MicroGate FPGA serial controller (2 or 4 ports)
- PCI 3.0 (compatible with 5V, 3.3V, and PCI-X slots)
- Bus Master DMA data transfer
- Environmental: Temperature 0C to 60C standard, -40C to +85C optional; humidity 0 to 95% non-condensing; alt. - 200 to +10,000 ft
- Mechanical: Standard PCI short card; length 6.875", height 4.2", Weight 5.5 Oz
- Power usage: 300mA 5V, 80mA +12V, 80mA -12V
- Regulatory: FCC Class B, CE, ANSI C63.4 Class B, VCCI Class B, EN55022 Class B, EN55024, RoHS
- Connectors: DB-25 (male)
- Cable Options: DB-25 (female) to DB-25 (male); DB-25 (female) to 34-pin V.35 (male); DB-25 (female) to 37-pin RS-449 (male); DB-25 (female) to 15-pin X.21 (male)

Y-Cables

The card has two 60-pin connectors, each carrying two ports. Y-cables are included with the card to convert each 60-pin connector into two standard DB-25 male connectors. The GT2 card uses one 60-pin connector and includes a single Y-cable for a total of 2 ports. The GT4 card uses both 60-pin connectors and includes two Y-cables for a total of 4 ports. Each branch of a Y-cable is labeled with a port number. The Y-cable labeled 1 and 2 should be installed on the 60-pin connector closest to the PCI edge connector (gold fingers). The Y-cable labeled 3 and 4 should be installed on the 60-pin connector farthest from the PCI edge connector.

Note: The serial controller on the GT2 has only two ports. Adding a Y-cable to the second 60-pin connector of a GT2 card will not add ports 3 and 4.

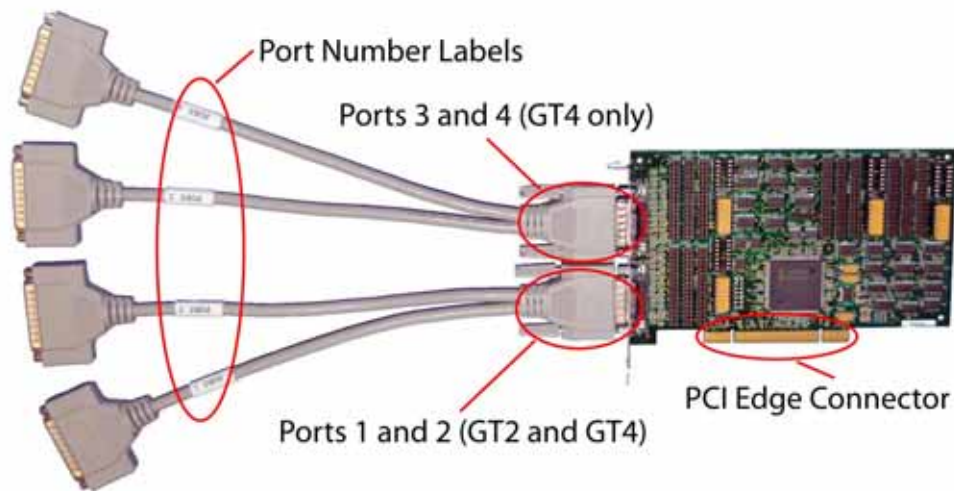

Figure 1 Y-Cables and Port Numbering

Signal Specifications

Each serial signal (control, status, data, or clock) is compatible with an electrical specification that is selected by placement of jumpers on the card. This section briefly describes the specifications supported by the card.

Single Ended Signals (RS-232/V.28)

Single ended signals supported by the card are compatible with both RS-232 and ITU V.28 standards. Each single ended signal uses one conductor in a cable, and all single ended signals share a common ground conductor.

- Maximum Voltage Range: +15 to -15V (between signal and ground)
- +3V to +15V (+5V typical) = control/status signal on or data value of 0
- -3V to -15V (-5V typical) = control/status signal off or data value of 1
- Voltage between -3V to +3V = invalid (indeterminate) state
- Max cable length 50 feet
- Max data rate 20kbps

The maximum data rate of 20kbps is part of the RS-232/V.28 standards. The SyncLink card can operate at speeds up to 120kbps depending on the cable length and loading. Longer cables and increased loading reduces the maximum supported data rate.

Differential Signals (RS-422/RS-485/V.11)

Differential signals supported by the card are compatible with RS-422, RS-485 and ITU V.11 standards. Each differential signal uses two conductors in a cable (signal pair). A common ground conductor is recommended for use with differential signals to reduce common mode voltages between cable ends which may result in incorrect or impaired operation.

- Maximum Voltage Range: +5 to -5V (between conductors in a pair)
- +200mV to +5V (+2V typical) = control/status signal on or data value of 0
- -200mV to -5V (-2V typical) = control/status signal off or data value of 1
- Voltage between -200mV to +200mV invalid (indeterminate) state
- Max cable length 4000 feet
- Max data rate 10Mbps

Longer cables and increased loading reduces the maximum supported data rate.

Clock Polarity

Synchronous serial communications (HDLC/Bisync/Monosync) may use separate clock signals to control the timing of data signals. One clock cycle equals one bit. There are two clock edges (rising and falling) for each clock cycle. On one edge, the transmit data output changes. On the other edge, the receive data input is sampled. The assignment of clock edges to transmit data transition and receive data sampling is referred to as clock polarity.

The SynLink card uses the clock polarity in the RS-232/RS-422/V.24/V.28/V.11 standards as described below:

RS-232/V.28 Single Ended Signals

- +3V to +15V (+5V typical) = clock on
- -3V to -15V (-5V typical) = clock off
- On to Off edge (falling edge) = transmit data transition (bit edge)
- Off to On edge(rising edge) = receive data sample (bit center)

RS-422/RS-485/V.11 Differential Signals

- +200mV to +5V (+2V typical) = clock on
- -200mV to -5V (-2V typical) = clock off
- On to Off edge (falling edge) = transmit data transition (bit edge)
- Off to On edge(rising edge) = receive data sample (bit center)

Most serial communications equipment uses the above clock polarity, but some non-standard equipment may use the opposite polarity. For differential signals, the polarity can be altered by inverting the conductors of each clock signal pair.

Serial Interface Selection

The serial adapter supports different interface types which are selected by placement of jumpers on the card. Each port has three rows of headers (pins sticking up from the card). Each row is labeled with a port number and an interface type (RS-232, V.35, RS-422/485). Place jumpers on the header row labeled with the desired interface type. The interface type must match that of the connected communications equipment.

Interface selection is preset at the factory as specified by the ordering code. The selection may be changed by moving the jumpers to the desired header row as described above. Use pliers to remove the jumpers from the current position, carefully working the jumpers loose from the headers. Take care to not damage the card or cause injury.

Some interface types require a conversion cable in addition to a specific jumper setting to provide the necessary connector type. Refer to the Serial Pin Assignments section for more details.

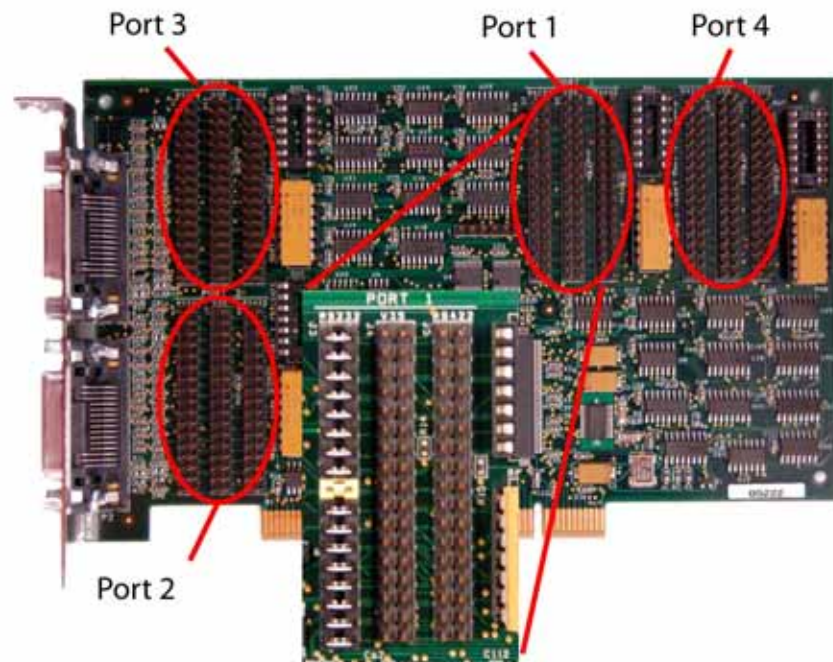

Port 1 Closeup (RS-232 Selected)

Figure 2 Interface Selection Jumpers

Differential Input Termination

Each port on the card has optional termination of RS-422/485 differential inputs. When a resistor pack is installed in the socket labeled 'TERM', all differential inputs for that port are terminated with 120 ohms. By default the termination resistor pack is installed for all ports. The presence of the termination resistor pack does not affect single ended (RS-232/V.28) inputs.

Termination is used to increase signal reliability at high speeds (generally 1Mbps or more). At high speeds, receivers at each end of a cable should be terminated. For a multi-drop setups (more than 2 devices on a cable), do not terminate receivers connected to the middle of the cable. At slower speeds, the termination can usually remain without problem. Removing termination at slower speeds may allow the use of longer cables.

To remove a termination resistor pack, identify the socket labeled 'TERM'. Then remove the yellow resistor pack from the black socket using a flat head screw driver or equivalent tool. Termination can be reinstalled by pressing the resistor pack back into the socket. Take care that the pins on the resistor pack are not bent and are firmly seated into the socket.

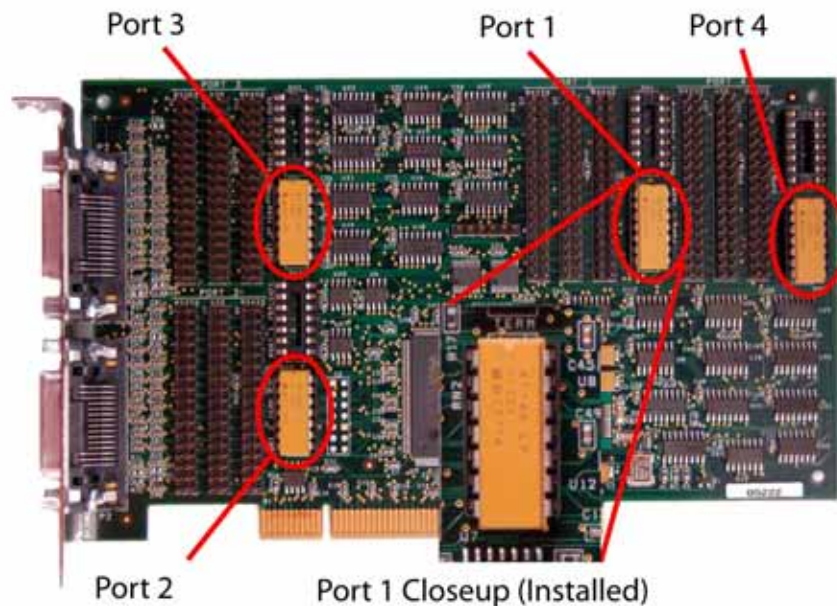

Figure 3 Termination Sockets

Differential Fail-Safe Biasing

Fail-safe biasing is a technique that guarantees differential input signals are in a steady state when not connected to an active differential output. Optional fail-safe biasing of all differential inputs (RS-422/RS-485/V.11) for a port is available by installing a resistor pack in the socket labeled 'FAILSAFE'. This resistor pack is not included by default with the hardware. Contact MicroGate sales to request fail-safe resistor packs when ordering the hardware.

Fail-safe biasing is only used when an input is not constantly driven by an output, and that input is terminated (see previous section on differential input termination). When an input is not terminated, fail-safe biasing integral to each receiver circuit maintains the input in a steady state. When an input is terminated, external fail-safe biasing (resistor pack) may be required to guarantee the input is in a steady state.

An example application that uses fail-safe biasing is bus mode connections where a single cable conductor pair is connected to both the transmit data output and receive data input for more than one station. In this setup, only one output may be active at the same time and each output is only driven when sending data. When no station is sending, the external fail-safe biasing maintains a voltage on the cable pair that keeps inputs in a steady state.

WARNING: Fail-safe biasing must be present on only a single station connected to a cable pair. This single station maintains the voltage on the cable to keep all connected inputs in a steady state. Applying fail-safe biasing at multiple points on a cable may result in incorrect operation.

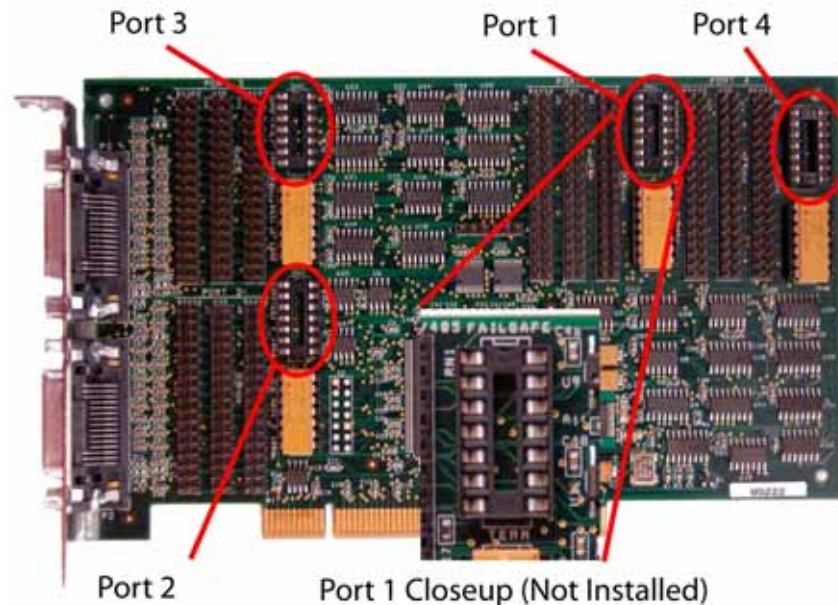

Figure 4 Fail Safe Biasing Sockets

Serial Connector Pin Assignments

The serial connectors on the end of each branch of the Y-cable are DB-25 (25 pins) male connectors. The assignment of signals to the connector pins is controlled by the interface selection jumpers on the card. For interface types that use a connector different than DB-25 an adapter cable purchased from MicroGate is required. The following sections describe the jumper settings and cables for each supported standard.

RS-232

The RS-232 standard uses single ended signals on a DB-25 connector. The adapter DB-25 connector follows this standard when the port jumpers are installed for RS-232. Use any straight through 25 conductor DB-25M to DB-25F cable (such as MicroGate Part # CMF000) to connect the adapter connector to the communications equipment.

The maximum data rate supported by the adapter when using RS-232 is 128Kbps. Cable length and signal loading may reduce the maximum usable data rate from this value.

RS-232 DB-25 Male DTE			
Signal Name	Electrical Desc	Pin #	Direction
Earth/Shield Ground		1	
TxD, Transmit Data	RS-232/V.28	2	Output
RxD, Receive Data	RS-232/V.28	3	Input
RTS, Request to Send	RS-232/V.28	4	Output
CTS, Clear to Send	RS-232/V.28	5	Input
DSR, Data Set Ready	RS-232/V.28	6	Input
Signal Ground		7	
DCD, Data Carrier Detect	RS-232/V.28	8	Input
TxC, Transmit Clock	RS-232/V.28	15	Input
RxC, Receive Clock	RS-232/V.28	17	Input
LL, Local Loopback Control	RS-232/V.28	18	Output
DTR, Data Terminal Ready	RS-232/V.28	20	Output
RL, Remote Loopback Control	RS-232/V.28	21	Output
RI, Ring Indicator	RS-232/V.28	22	Input
AuxClk, DTE Clock Output	RS-232/V.28	24	Output



Figure 5 RS-232 Cable (Part# CMF000)

V.35

The V.35 standard uses a mix of single ended and differential signals on a 34 pin block connector. To use this standard, install the V.35 jumpers on the port and use the MicroGate V.35 cable (Part # 2534GT, picture shown below).

Note that the LL, RL, and RI signals are available on the adapter's DB-25 connector when the V.35 jumpers are installed, but are not available (NC = no connect) on the 34 pin block connector when using the V.35 cable.

The maximum data rate supported by the adapter when using V.35 is 10Mbps. Cable length and signal loading may reduce the maximum usable data rate from this value.

V.35 Male DTE				
Signal Name	Electrical Desc	DB25 Pin #	V.35 Block Pin #	Direction
Earth/Shield Ground		1	A	
TxD (+/A), Transmit Data	RS-422/V.11	2	P	Output
RxD (+/A), Receive Data	RS-422/V.11	3	R	Input
RTS, Request to Send	RS-232/V.28	4	C	Output
CTS, Clear to Send	RS-232/V.28	5	D	Input
DSR, Data Set Ready	RS-232/V.28	6	E	Input
Signal Ground		7	B	
DCD, Data Carrier Detect	RS-232/V.28	8	F	Input
RxC (-/B), Receive Clock	RS-422/V.11	9	X	Input
AuxClk (-/B), DTE Clock Output	RS-422/V.11	11	W	Output
TxC (-/B), Transmit Clock	RS-422/V.11	12	AA	Input
TxD (-/B), Transmit Data	RS-422/V.11	14	S	Output
TxC (+/A), Transmit Clock	RS-422/V.11	15	Y	Input
RxD (-/B), Receive Data	RS-422/V.11	16	T	Input
RxC (+/A), Receive Clock	RS-422/V.11	17	V	Input
LL, Local Loopback Control	RS-232/V.28	18	NC	Output
DTR, Data Terminal Ready	RS-232/V.28	20	H	Output
RL, Remote Loopback Control	RS-232/V.28	21	NC	Output
RI, Ring Indicator	RS-232/V.28	22	NC	Input
AuxClk (+/A), DTE Clock Output	RS-422/V.11	24	24	Output



Figure 6 V.35 Cable (Part# 2534GT)

RS-422/RS-449/RS-485/RS-530

The RS-422 and RS-485 standards describe differential electrical signals but not connector or pin assignments. The RS-530 and RS-449 standards define specific connectors and pin assignments using differential signals. The differential signals on the card meet both RS-422 and RS-485 electrical specifications.

RS-530 uses differential signals on a DB-25 connector. The adapter DB-25 connector follows this standard when the port jumpers are installed for RS-422/485. Use any straight through 25 conductor DB-25M to DB-25F cable (such as MicroGate Part # CMF000) to connect the adapter to RS-530 communications equipment.

RS-449 uses differential signals on a DB-37 connector. To use this standard install the RS-422/485 jumpers for the port and use the MicroGate RS-449 cable (Part # 2537FM).

The maximum data rate supported by the adapter when using RS-530 or RS-449 is 10Mbps. Cable length and signal loading may reduce the maximum usable data rate from this value.

RS-422/RS-530/RS-449 Male DTE				
Signal Name	Electrical Desc	DB25 RS-530 Pin #	DB37 RS-449 Pin #	Direction
Earth/Shield Ground		1	1	
TxD (+/A), Transmit Data	RS-422/V.11	2	4	Output
RxD (+/A), Receive Data	RS-422/V.11	3	6	Input
RTS (+/A), Request to Send	RS-422/V.11	4	7	Output
CTS (+/A), Clear to Send	RS-422/V.11	5	9	Input
DSR (+/A), Data Set Ready	RS-422/V.11	6	11	Input
Signal Ground		7	19	
DCD (+/A), Data Carrier Detect	RS-422/V.11	8	13	Input
RxC (-/B), Receive Clock	RS-422/V.11	9	26	Input
DCD (-/B), Data Carrier Detect	RS-422/V.11	10	31	Input
AuxClk (-/B), DTE Clock Output	RS-422/V.11	11	35	Output
TxC (-/B), Transmit Clock	RS-422/V.11	12	23	Input
CTS (-/B), Clear to Send	RS-422/V.11	13	27	Input
TxD (-/B), Transmit Data	RS-422/V.11	14	22	Output
TxC (+/A), Transmit Clock	RS-422/V.11	15	5	Input
RxD (-/B), Receive Data	RS-422/V.11	16	24	Input
RxC (+/A), Receive Clock	RS-422/V.11	17	8	Input
LL, Local Loopback Control	RS-232/V.28	18	10	Output
RTS (-/B), Request to Send	RS-422/V.11	19	25	Output
DTR (+/A), Data Terminal Ready	RS-422/V.11	20	12	Output
RL, Remote Loopback Control	RS-232/V.28	21	14	Output
DSR (-/B), Data Set Ready	RS-422/V.11	22	29	Input
DTR (-/B), Data Terminal Ready	RS-422/V.11	23	30	Output
AuxClk (+/A), DTE Clock Output	RS-422/V.11	24	17	Output



Figure 7 RS-530 Cable (Part# CMF000)



Figure 8 RS-449 Cable (Part# 2537FM)

X.21

X.21 is an interface standard using differential signals on a DB-15 connector. To use this standard, install the RS-422/485 jumpers on a port and use the MicroGate X.21 cable (Part # 2515FM).

The X.21 signal names are different than those used by the adapter and other interface standards. The mapping of the X.21 signals to the adapter signals are shown in the table below.

The maximum data rate supported by the adapter when using X.21 is 10Mbps. Cable length and signal loading may reduce the maximum usable data rate from this value.

X.21 Male DTE				
Signal Name	Electrical Desc	DB25 Pin #	DB15 Pin #	Direction
Earth/Shield Ground		1	1	
T+, Transmit Data	RS-422/V.11	2	2	Output
R+, Receive Data	RS-422/V.11	3	4	Input
I+, Indicator (DSR/DCD)	RS-422/V.11	6,8	5	Input
Signal Ground		7	8	
S-, Clock Input (TxC, RxC)	RS-422/V.11	9,12	13	Input
I-, Indicator (DSR/DCD)	RS-422/V.11	10,22	12	Input
X-, Clock Output (AuxClk)	RS-422/V.11	11	14	Output
T-, Transmit Data	RS-422/V.11	14	9	Output
S+, Clock Input (TxC, RxC)	RS-422/V.11	15,17	6	Input
R-, Receive Data	RS-422/V.11	16	11	Input
C+, Control (DTR)	RS-422/V.11	20	3	Output
C-, Control (DTR)	RS-422/V.11	23	10	Output
X+, Clock Output (AuxClk)	RS-422/V.11	24	7	Output

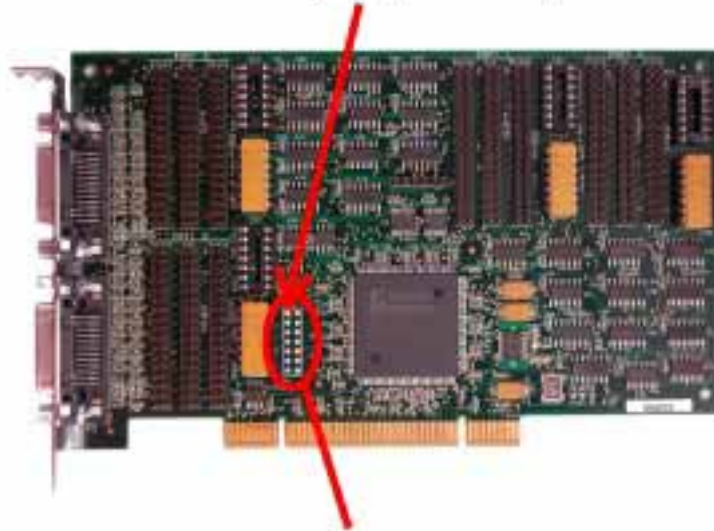

Figure 9 X.21 Cable (Part# 2515FM)

General Purpose I/O Signals

The serial card has an optional 14 pin header that provides general purpose input/output (GPIO) signals for application specific uses. These signals are controlled by an application using the serial API (Windows and Linux). Each signal can be configured to be either an input or an output. Inputs can be monitored and outputs can be controlled.

Pin 1 (upper left)



Optional GPIO Header (J2) Position

DC GPIO Specifications

Vil (input low) = -0.5V min, 0.8V max

Vih (input high) = 2.0V min, 5.5V max

Vol (output low) = 0.4V max

Voh (output high) = 2.4V min

Iol (output low) = 24mA max

Iih (output high) = -24mA max

Input Current = +/- 10uA max

GPIO signals are 3.3V TTL compatible and inputs are 5V tolerant.

GPIO Pin Assignments	
Pin #	Description
1	Ground
2	GCK0 Dedicated special purpose LVTTTL input – Leave unconnected
3	GPIO[6]
4	GPIO[0]
5	GPIO[7]
6	GPIO[1]
7	GPIO[8]
8	GPIO[2]
9	GPIO[9]
10	GPIO[3]
11	GPIO[10]
12	GPIO[4]
13	GPIO[11]
14	GPIO[5]

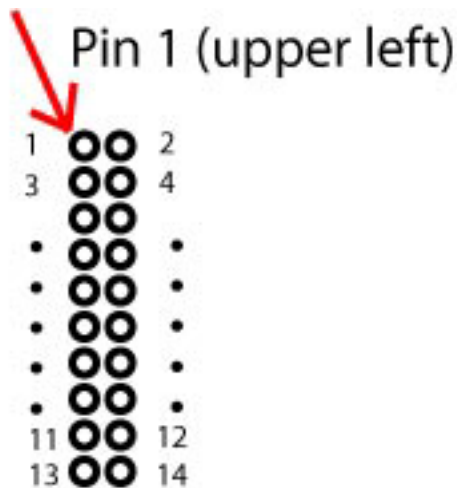

GPIO Header (J2) Pin Numbering

The GT adapter has a total of 12 general purpose I/O signals (GPIO[0] to GPIO[11]). By default on power up all GPIO signals are configured as inputs (direction control = 0). Refer to the serial API documentation for details on configuring and using GPIO signals.

WARNING: Take care when connecting to GPIO signals to prevent damage to the serial card. Outputs should only be connected to inputs and not other outputs. Voltage limits as shown above should not be exceeded.

