

SyncLink GT2E/GT4E Serial Adapter

Hardware User's Manual



MicroGate Systems, Ltd
13279 Pond Springs Rd #6
Austin, TX 78729
<http://www.microgate.com>

MicroGate® and SyncLink® are registered trademarks of MicroGate Systems, Ltd.
Copyright © 2008-2009 MicroGate Systems, Ltd. All Rights Reserved

Contents

Overview	3
Features	3
Specifications	3
PCI Express	3
Y-Cables.....	4
Signal Specifications.....	5
Single Ended Signals (RS-232/V.28)	5
Differential Signals (RS-422/RS-485/V.11).....	5
Clock Polarity	5
Serial Interface Selection	7
Differential Input Termination.....	8
2 Wire Mode Jumpers.....	9
Serial Connector Pin Assignments	10
RS-232	11
V.35	12
RS-422/RS-449/RS-485/RS-530.....	13
X.21	15
General Purpose I/O Signals	16
DC GPIO Specifications.....	16
Frequency Synthesizer	18

Overview

The SyncLink GT2E and GT4E Serial Adapters are add-in cards for use in systems with a PCI Express expansion slot. The cards provide two (GT2E) or four (GT4E) serial ports for use by the system. A variety of serial protocols and interface standards are supported. Refer to the software documentation included with the card for details on using the card for a specific application.

Features

- Maximum Speeds
 - 10Mbps synchronous
 - 8Mbps asynchronous
- SDLC, HDLC, BISYNC, MONOSYNC, ASYNC, raw bit-synchronous protocols
- Selectable hardware CRC: CRC-16, CRC-32, None
- DPLL Clock Recovery (x8 and x16 sampling)
- Clock Generation
- Configurable transmit preamble and idle patterns
- Encoding: NRZ, NRZB, NRZ-L, NRZI, NRZ-M, NRZ-S, FM0, FM1, Manchester, differential biphasic level
- Selectable interface for RS-232, V.35, RS-422/485, RS-530, RS-449, X.21
- Optional termination for differential inputs
- Optional fail safe biasing for differential inputs
- Full set of control and status signals (DTR, DSR, RTS, CTS, DCD, RI, LL, RL)

Specifications

- MicroGate FPGA serial controller (2 or 4 ports)
- PCI Express (x1)
- Bus Master DMA data transfer
- Environmental: Temperature 0C to 60C standard, -40C to +85C optional; humidity 0 to 95% non-condensing; alt. - 200 to +10,000 ft
- Mechanical: Standard PCI Express short card; length 6.6", height 4.2", Weight 4.4 Oz
- Power usage: 1A 3.3V
- Regulatory: FCC Class B, CE, ANSI C63.4 Class B, VCCI Class B, EN55022 Class B, EN55024, RoHS
- Connectors: DB-25 (male)
- Cable Options: DB-25 (female) to DB-25 (male); DB-25 (female) to 34-pin V.35 (male); DB-25 (female) to 37-pin RS-449 (male); DB-25 (female) to 15-pin X.21 (male)

PCI Express

PCI Express is an expansion slot standard for adding components to a system. PCI Express is not physically compatible with PCI or PCI-X slots. SyncLink cards are physically keyed to prevent insertion into incompatible slots. The SyncLink GT2E and GT4E are PCI Express x1 single lane cards. This means SyncLink cards work in any of the different PCI Express slots sizes (x1, x4, x8, or x16). PCI Express x1 slots are the shortest and x16 slots are the longest.

Y-Cables

The card has two 60-pin connectors, each carrying two ports. Y-cables are included with the card to convert each 60-pin connector into two standard DB-25 male connectors. The GT2E card uses one 60-pin connector and includes a single Y-cable for a total of 2 ports. The GT4E card uses both 60-pin connectors and includes two Y-cables for a total of 4 ports. Each branch of a Y-cable is labeled with a port number. The Y-cable labeled 1 and 2 should be installed on the 60-pin connector closest to the PCI Express edge connector (gold fingers). The Y-cable labeled 3 and 4 should be installed on the 60-pin connector farthest from the PCI edge connector.

Note: The serial controller on the GT2E has only two ports. Adding a Y-cable to the second 60-pin connector of a GT2E card will not add ports 3 and 4.

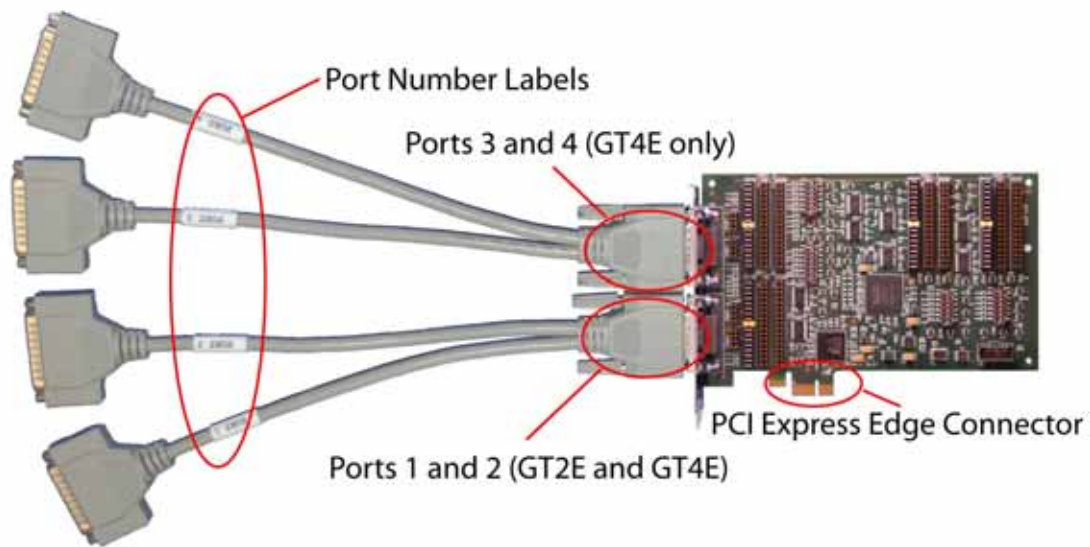

Signal Specifications

Each serial signal (control, status, data, or clock) is compatible with an electrical specification that is selected by placement of jumpers on the card. This section briefly describes the specifications supported by the card.

Single Ended Signals (RS-232/V.28)

Single ended signals supported by the card are compatible with both RS-232 and ITU V.28 standards. Each single ended signal uses one conductor in a cable, and all single ended signals share a common ground conductor.

- Maximum Voltage Range: +15 to -15V (between signal and ground)
- +3V to +15V (+5V typical) = control/status signal on or data value of 0
- -3V to -15V (-5V typical) = control/status signal off or data value of 1
- Voltage between -3V to +3V = invalid (indeterminate) state
- Max cable length 50 feet
- Max data rate 20kbps

The maximum data rate of 20kbps is part of the RS-232/V.28 standards. The SyncLink card can operate at speeds up to 120kbps depending on the cable length and loading. Longer cables and increased loading reduces the maximum supported data rate.

Differential Signals (RS-422/RS-485/V.11)

Differential signals supported by the card are compatible with RS-422, RS-485 and ITU V.11 standards. Each differential signal uses two conductors in a cable (signal pair). A common ground conductor is recommended for use with differential signals to reduce common mode voltages between cable ends which may result in incorrect or impaired operation.

- Maximum Voltage Range: +5 to -5V (between conductors in a pair)
- +200mV to +5V (+2V typical) = control/status signal on or data value of 0
- -200mV to -5V (-2V typical) = control/status signal off or data value of 1
- Voltage between -200mV to +200mV invalid (indeterminate) state
- Max cable length 4000 feet
- Max data rate 10Mbps

Longer cables and increased loading reduces the maximum supported data rate.

Clock Polarity

Synchronous serial communications (HDLC/Bisync/Monosync) may use separate clock signals to control the timing of data signals. One clock cycle equals one bit. There are two clock edges (rising and falling) for each clock cycle. On one edge, the transmit data output changes. On the other edge, the receive data input is sampled. The assignment of clock edges to transmit data transition and receive data sampling is referred to as clock polarity.

The SynLink card uses the clock polarity in the RS-232/RS-422/V.24/V.28/V.11 standards as described below:

RS-232/V.28 Single Ended Signals

- +3V to +15V (+5V typical) = clock on
- -3V to -15V (-5V typical) = clock off
- On to Off edge (falling edge) = transmit data transition (bit edge)
- Off to On edge(rising edge) = receive data sample (bit center)

RS-422/RS-485/V.11 Differential Signals

- +200mV to +5V (+2V typical) = clock on
- -200mV to -5V (-2V typical) = clock off
- On to Off edge (falling edge) = transmit data transition (bit edge)
- Off to On edge(rising edge) = receive data sample (bit center)

Most serial communications equipment uses the above clock polarity, but some non-standard equipment may use the opposite polarity. For differential signals, the polarity can be altered by inverting the conductors of each clock signal pair.

Serial Interface Selection

The serial adapter supports different interface types which are selected by placement of jumpers on the card. Each port has three rows of headers (pins sticking up from the card). Each row is labeled with a port number and an interface type (RS-232, V.35, RS-422/485). Place jumpers on the header row labeled with the desired interface type. The interface type must match that of the connected communications equipment.

Interface selection is preset at the factory as specified by the ordering code. The selection may be changed by moving the jumpers to the desired header row as described above. Use pliers to remove the jumpers from the current position, carefully working the jumpers loose from the headers. Take care to not damage the card or cause injury.

Some interface types require a conversion cable in addition to a specific jumper setting to provide the necessary connector type. Refer to the Serial Pin Assignments section for more details.

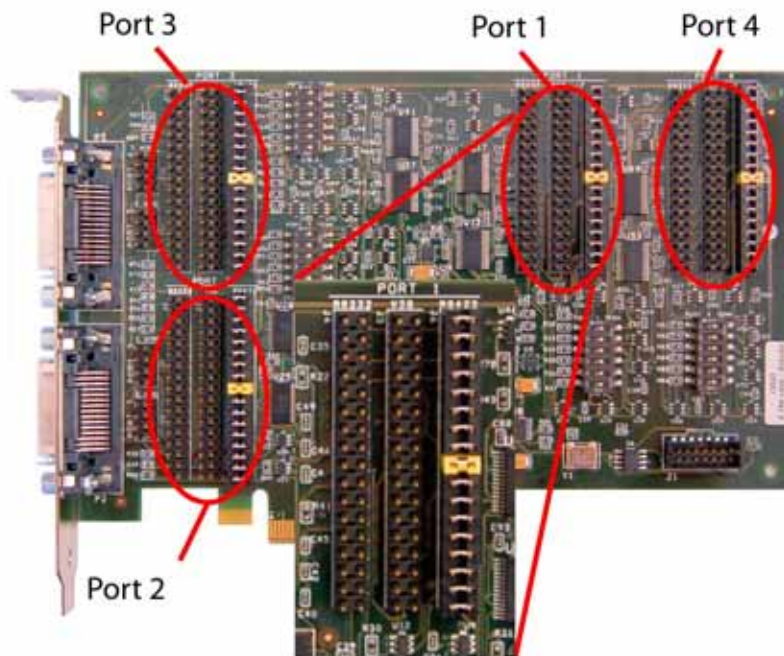

Port 1 Closeup (RS-422/RS-485 Selected)

Figure 2 Interface Selection Jumpers

Differential Input Termination

Each port on the card has optional termination of RS-422/485 differential inputs controlled by a six position switch labeled with a port number and the word 'TERM'. Each position is labeled with a number (1 at top through 6 at bottom). The on position is to the right and is labeled 'ON'. When a switch is in the ON position, the associated differential input is terminated with 120 ohms. By default all inputs are terminated for all ports. Termination settings do not affect single ended (RS-232/V.28) inputs.

Termination increases signal reliability at high speeds (generally 1Mbps or more). At high speeds, inputs at each end of a cable should be terminated. For a multi-drop setups (more than 2 devices on a cable), do not terminate receivers connected to the middle of the cable. At slower speeds, the termination can usually remain without problem. Removing termination at slower speeds may allow the use of longer cables.

To disable termination on an input, move the associated switch position to OFF.

Switch Position	Signal Name
1	TxC (Transmit Clock)
2	RxC (Receive Clock)
3	RxD (Receive Data)
4	CTS (Clear to Send)
5	DSR (Data Set Ready)
6	DCD (Data Carrier Detect)

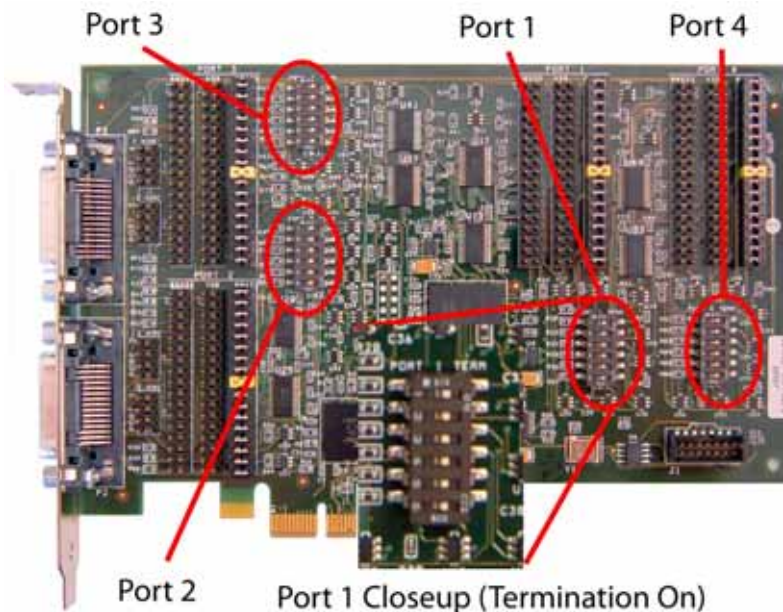

Figure 3 Termination Switches

2 Wire Mode Jumpers

Some RS-485 applications use a single differential wire pair to carry data instead of separate pair for transmit and receive data. This arrangement is sometimes called '2 wire' and is useful for minimizing wiring for connecting multiple end points. Only one end point sends data at any time, and all other end points can receive the data.

The GT4e card by default has separate transmit and receive data signals on different pins of the serial connector. Jumpers can be installed to connect transmit and receive pins together for use in a 2 wire environment. The jumpers are located next to the serial connector and are labeled with the port number and the text '2 WIRE'.

WARNING

The 2 wire jumpers should **never** be installed on ports configured for RS-232 to avoid damaging the card. The jumpers should only be installed when configured for RS-422/RS-485 **and** the application requires a common cable pair for transmit and receive data.

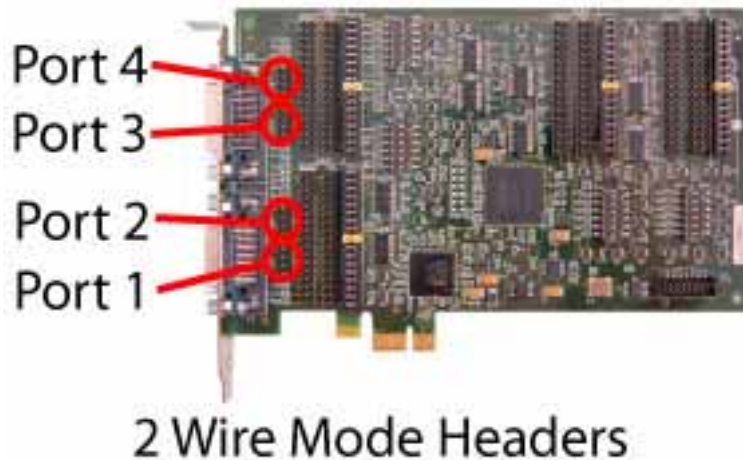

Jumpers are placed horizontally across the header pins. Each signal requires two jumpers to connect the two conductors of each differential pair. The drawing below identifies the header pins. Usually only TxD and RxD are connected (jumpers installed across pins 1 - 2 and 3 - 4).



2-Wire Header Pin Numbering

Serial Connector Pin Assignments

The serial connectors on the end of each branch of the Y-cable are DB-25 (25 pins) male connectors. The assignment of signals to the connector pins is controlled by the interface selection jumpers on the card. For interface types that use a connector different than DB-25 an adapter cable purchased from MicroGate is required. The following sections describe the jumper settings and cables for each supported standard.

RS-232

The RS-232 standard uses single ended signals on a DB-25 connector. The adapter DB-25 connector follows this standard when the port jumpers are installed for RS-232. Use any straight through 25 conductor DB-25M to DB-25F cable (such as MicroGate Part # CMF000) to connect the adapter connector to the communications equipment.

The maximum data rate supported by the adapter when using RS-232 is 128Kbps. Cable length and signal loading may reduce the maximum usable data rate from this value.

RS-232 DB-25 Male DTE			
Signal Name	Electrical Desc	Pin #	Direction
Earth/Shield Ground		1	
TxD, Transmit Data	RS-232/V.28	2	Output
RxD, Receive Data	RS-232/V.28	3	Input
RTS, Request to Send	RS-232/V.28	4	Output
CTS, Clear to Send	RS-232/V.28	5	Input
DSR, Data Set Ready	RS-232/V.28	6	Input
Signal Ground		7	
DCD, Data Carrier Detect	RS-232/V.28	8	Input
TxC, Transmit Clock	RS-232/V.28	15	Input
RxC, Receive Clock	RS-232/V.28	17	Input
LL, Local Loopback Control	RS-232/V.28	18	Output
DTR, Data Terminal Ready	RS-232/V.28	20	Output
RL, Remote Loopback Control	RS-232/V.28	21	Output
RI, Ring Indicator	RS-232/V.28	22	Input
AuxClk, DTE Clock Output	RS-232/V.28	24	Output



Figure 5 RS-232 Cable (Part# CMF000)

V.35

The V.35 standard uses a mix of single ended and differential signals on a 34 pin block connector. To use this standard, install the V.35 jumpers on the port and use the MicroGate V.35 cable (Part # 2534GT, picture shown below).

Note that the LL, RL, and RI signals are available on the adapter's DB-25 connector when the V.35 jumpers are installed, but are not available (NC = no connect) on the 34 pin block connector when using the V.35 cable.

The maximum data rate supported by the adapter when using V.35 is 10Mbps. Cable length and signal loading may reduce the maximum usable data rate from this value.

V.35 Male DTE				
Signal Name	Electrical Desc	DB25 Pin #	V.35 Block Pin #	Direction
Earth/Shield Ground		1	A	
TxD (+/A), Transmit Data	RS-422/V.11	2	P	Output
RxD (+/A), Receive Data	RS-422/V.11	3	R	Input
RTS, Request to Send	RS-232/V.28	4	C	Output
CTS, Clear to Send	RS-232/V.28	5	D	Input
DSR, Data Set Ready	RS-232/V.28	6	E	Input
Signal Ground		7	B	
DCD, Data Carrier Detect	RS-232/V.28	8	F	Input
RxC (-/B), Receive Clock	RS-422/V.11	9	X	Input
AuxClk (-/B), DTE Clock Output	RS-422/V.11	11	W	Output
TxC (-/B), Transmit Clock	RS-422/V.11	12	AA	Input
TxD (-/B), Transmit Data	RS-422/V.11	14	S	Output
TxC (+/A), Transmit Clock	RS-422/V.11	15	Y	Input
RxD (-/B), Receive Data	RS-422/V.11	16	T	Input
RxC (+/A), Receive Clock	RS-422/V.11	17	V	Input
LL, Local Loopback Control	RS-232/V.28	18	NC	Output
DTR, Data Terminal Ready	RS-232/V.28	20	H	Output
RL, Remote Loopback Control	RS-232/V.28	21	NC	Output
RI, Ring Indicator	RS-232/V.28	22	NC	Input
AuxClk (+/A), DTE Clock Output	RS-422/V.11	24	24	Output



Figure 6 V.35 Cable (Part# 2534GT)

RS-422/RS-449/RS-485/RS-530

The RS-422 and RS-485 standards describe differential electrical signals but not connector or pin assignments. The RS-530 and RS-449 standards define specific connectors and pin assignments using differential signals. The differential signals on the card meet both RS-422 and RS-485 electrical specifications.

RS-530 uses differential signals on a DB-25 connector. The adapter DB-25 connector follows this standard when the port jumpers are installed for RS-422/485. Use any straight through 25 conductor DB-25M to DB-25F cable (such as MicroGate Part # CMF000) to connect the adapter to RS-530 communications equipment.

RS-449 uses differential signals on a DB-37 connector. To use this standard install the RS-422/485 jumpers for the port and use the MicroGate RS-449 cable (Part # 2537FM).

The maximum data rate supported by the adapter when using RS-530 or RS-449 is 10Mbps. Cable length and signal loading may reduce the maximum usable data rate from this value.

RS-422/RS-530/RS-449 Male DTE				
Signal Name	Electrical Desc	DB25 RS-530 Pin #	DB37 RS-449 Pin #	Direction
Earth/Shield Ground		1	1	
TxD (+/A), Transmit Data	RS-422/V.11	2	4	Output
RxD (+/A), Receive Data	RS-422/V.11	3	6	Input
RTS (+/A), Request to Send	RS-422/V.11	4	7	Output
CTS (+/A), Clear to Send	RS-422/V.11	5	9	Input
DSR (+/A), Data Set Ready	RS-422/V.11	6	11	Input
Signal Ground		7	19	
DCD (+/A), Data Carrier Detect	RS-422/V.11	8	13	Input
RxC (-/B), Receive Clock	RS-422/V.11	9	26	Input
DCD (-/B), Data Carrier Detect	RS-422/V.11	10	31	Input
AuxClk (-/B), DTE Clock Output	RS-422/V.11	11	35	Output
TxC (-/B), Transmit Clock	RS-422/V.11	12	23	Input
CTS (-/B), Clear to Send	RS-422/V.11	13	27	Input
TxD (-/B), Transmit Data	RS-422/V.11	14	22	Output
TxC (+/A), Transmit Clock	RS-422/V.11	15	5	Input
RxD (-/B), Receive Data	RS-422/V.11	16	24	Input
RxC (+/A), Receive Clock	RS-422/V.11	17	8	Input
LL, Local Loopback Control	RS-232/V.28	18	10	Output
RTS (-/B), Request to Send	RS-422/V.11	19	25	Output
DTR (+/A), Data Terminal Ready	RS-422/V.11	20	12	Output
RL, Remote Loopback Control	RS-232/V.28	21	14	Output
DSR (-/B), Data Set Ready	RS-422/V.11	22	29	Input
DTR (-/B), Data Terminal Ready	RS-422/V.11	23	30	Output
AuxClk (+/A), DTE Clock Output	RS-422/V.11	24	17	Output



Figure 7 RS-530 Cable (Part# CMF000)



Figure 8 RS-449 Cable (Part# 2537FM)

X.21

X.21 is an interface standard using differential signals on a DB-15 connector. To use this standard, install the RS-422/485 jumpers on a port and use the MicroGate X.21 cable (Part # 2515FM).

The X.21 signal names are different than those used by the adapter and other interface standards. The mapping of the X.21 signals to the adapter signals are shown in the table below.

The maximum data rate supported by the adapter when using X.21 is 10Mbps. Cable length and signal loading may reduce the maximum usable data rate from this value.

X.21 Male DTE				
Signal Name	Electrical Desc	DB25 Pin #	DB15 Pin #	Direction
Earth/Shield Ground		1	1	
T+, Transmit Data	RS-422/V.11	2	2	Output
R+, Receive Data	RS-422/V.11	3	4	Input
I+, Indicator (DSR/DCD)	RS-422/V.11	6,8	5	Input
Signal Ground		7	8	
S-, Clock Input (TxC, RxC)	RS-422/V.11	9,12	13	Input
I-, Indicator (DSR/DCD)	RS-422/V.11	10,22	12	Input
X-, Clock Output (AuxClk)	RS-422/V.11	11	14	Output
T-, Transmit Data	RS-422/V.11	14	9	Output
S+, Clock Input (TxC, RxC)	RS-422/V.11	15,17	6	Input
R-, Receive Data	RS-422/V.11	16	11	Input
C+, Control (DTR)	RS-422/V.11	20	3	Output
C-, Control (DTR)	RS-422/V.11	23	10	Output
X+, Clock Output (AuxClk)	RS-422/V.11	24	7	Output



Figure 9 X.21 Cable (Part# 2515FM)

General Purpose I/O Signals

The serial card has an optional 14 pin header that provides general purpose input/output (GPIO) signals for application specific uses. These signals are controlled by an application using the serial API (Windows and Linux). Each signal can be configured to be either an input or an output. Inputs can be monitored and outputs can be controlled.

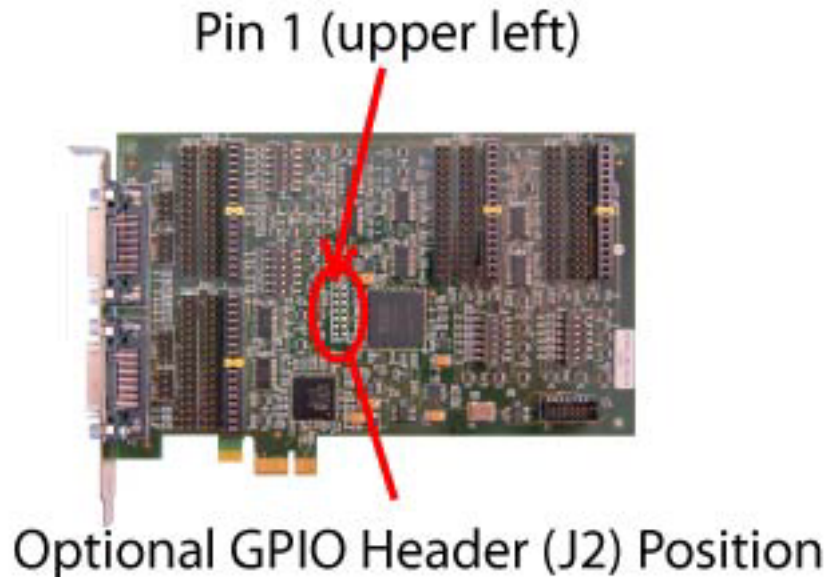

DC GPIO Specifications

V_{il} (input low) = -0.5V min, 0.8V max

V_{ih} (input high) = 2.0V min, 5.5V max

V_{ol} (output low) = 0.4V max

V_{oh} (output high) = 2.4V min

I_{ol} (output low) = 24mA max

I_{ih} (output high) = -24mA max

Input Current = +/- 10uA max

GPIO signals are 3.3V TTL compatible and inputs are 5V tolerant.

GPIO Pin Assignments	
Pin #	Description
1	Ground
2	GCK0 Dedicated special purpose LVTTTL input – Leave unconnected
3	GPIO[6]
4	GPIO[0]
5	GPIO[7]
6	GPIO[1]
7	GPIO[8]
8	GPIO[2]
9	GPIO[9]
10	GPIO[3]
11	GPIO[10]
12	GPIO[4]
13	GPIO[11]
14	GPIO[5]

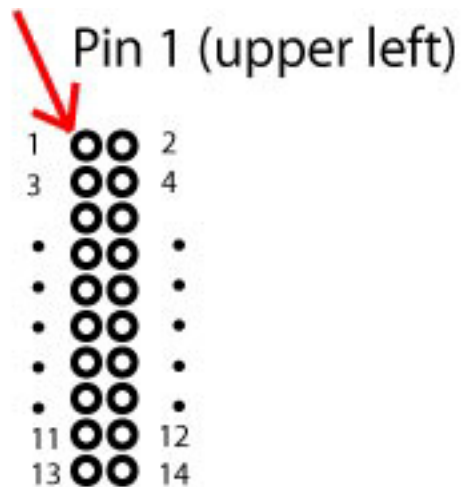

GPIO Header (J2) Pin Numbering

The GT adapter has a total of 12 general purpose I/O signals (GPIO[0] to GPIO[11]). By default on power up all GPIO signals are configured as inputs (direction control = 0). Refer to the serial API documentation for details on configuring and using GPIO signals.

WARNING: Take care when connecting to GPIO signals to prevent damage to the serial card. Outputs should only be connected to inputs and not other outputs. Voltage limits as shown above should not be exceeded.

Frequency Synthesizer

The serial controller requires a base clock which is used by the baud rate generator (BRG) to create data clocks. A data clock may be output on the AUXCLK signal or used internally for a synchronous data clock, an asynchronous sampling clock, or for DPLL clock recovery.

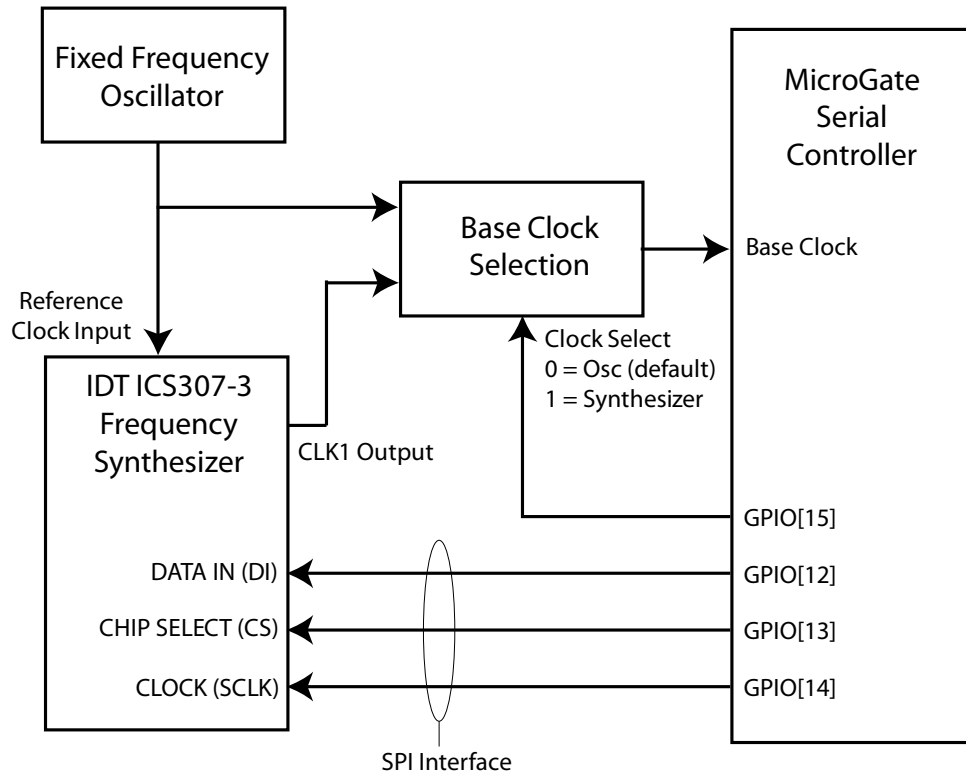

Base Clock Sources

The card has a fixed frequency oscillator and a variable frequency synthesizer. Either source can supply the base clock. The oscillator is used as the synthesizer reference clock input. Serial controller GPIO signals program the synthesizer through an SPI interface and select between the oscillator and synthesizer outputs. The base clock is common to all ports in the controller.

The synthesizer is made by Integrated Device Technologies (IDT). Refer to the documentation available from IDT (www.idt.com) for details on programming the synthesizer. An IDT supplied program (Versaclock) generates programming data (132 bit value) for a specific frequency output. The CLK1 output of the synthesizer is used, CLK2 and CLK3 are unconnected. Sample code for programming the synthesizer through the GPIO portion of the serial API is available from Microgate. The maximum synthesizer frequency supported by the serial controller is 66MHz.

The default oscillator frequency is 14.7456MHz. Other frequencies are available by special order. By default the serial controller uses the oscillator as the base clock.